



SPANISH PATENT AND  
TRADEMARK OFFICE

SPAIN

I I II IIIII 11111111111111111111

@Numero of publication: **2 943 782**

@Application number: 202131160

@int.Cl.:

**G01N 3/04** 12006.011

**G01N 3/08** 12006.011

**INVENTION PATENT WITH EXAMINATION**

B2

@Fecha of presentation:

**15.12.2021**

@) Date of publication of the application:

**15.06.2023**

Date of modification of claims:

**06.04.2022**

Date of grant:

**15.12.2023**

@ Grant Publication Date:

**22.12.2023**

@ Owner/s:

**UNIVERSITY OF CANTABRIA (100.0%)**

**Avenida de Los Castros 44**

**39005 SANTANDER (Cantabria) ES**

@ Inventor/s:

**FERRENO BLANCO, Diego;**

**RUIZ MARTINEZ, Estela;**

**ARROYO MARTINEZ, Borja;**

**CARRASCAL VAQUERO, Isidro;**

**PIEDRA LANZA, Rafael;**

**PASCUAL FERNANDEZ, Santiago;**

**RIVAS PELAYO, Isaac and**

**GUTIERREZ-SOLANA SALCEDO, Federico**

@ Agent/Representative:

**CAPTAIN GARCIA, Nuria**

@Tftulo: **ADAPTADO\_R FOR GRIPS OF A TENSILE-COMPRESSION TESTING MACHINE**

@Resumen:

Adapter for grips of a tensile-compression testing machine.

Adapter for grips of a tensile-compression testing machine, each jaw comprising a first major clamping face, a second and third major face and two side faces, the adapter comprises two prismatic plates, each attachable to each jaw and a fourth major face facing the third, a fifth side, a first and second minor face and two side faces, Each plate includes on its fifth major face a semi-cylindrical cupping whose longitudinal axis is aligned or parallel to the movement

of the jaws, so that two plates form a cylindrical housing for a cylindrical specimen of constant section, avoiding breakage in the gripping area, each plate is longer than the third major face, so that the fifth major face extends in a greater dimension than that of the corresponding third major face, achieving a smooth transition of efforts.

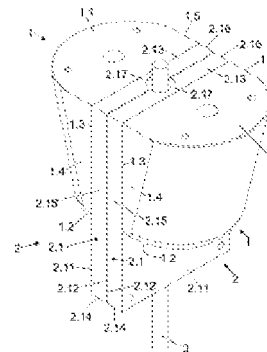

**Notice:** Consultation provided for in Article 41 may be carried out LP 24/2015.

Within six months following the publication of the concession in the Official Gazette of Industrial Property, any person may oppose the concession. The opposition must be addressed to the SPTO in a reasoned letter and after payment of the corresponding fee (Article 43 LP 24/2015).

b  
CV  
CO  
.....  
H  
to,  
H

CV  
in  
W

**DESCRIPTION**

**ADAPTER FOR GRIPS OF A TENSILE-COMPRESSION TESTING  
MACHINE**

5

**TECHNICAL FIELD OF INVENTION**

The present invention falls within the field of testing of specimen-sabre materials, in particular, tensile-compression-compression tests on testing machines  
10 for this purpose.

**BACKGROUND TO THE INVENTION**

Tensile-compression testing machines have been well known for  
15 time and are even commonly referred to as universal traction-compression machines due to their wide diffusion and acceptance. An illustrative example is the machines produced by the manufacturer Instron ([www.instron.com](http://www.instron.com)).

Some tensile-compression testing machines include grooved grips  
20 to fix specimens during a test. The pressure is applied by a hydraulic system, although there are other ways such as wedging systems in which the greater the tensile force applied, the greater the tightening of the specimen. In any of these cases, the jaws are in contact with the specimen at a certain length at each of its ends, exerting a pressure that prevents the  
25 Slippage of the specimen with respect to the jaws. The length of the specimen that is in contact with the jaws is called the "jaw region", while the length of the specimen that is not in contact with the jaws is called the "free region between jaws". The most demanding stress states on the specimen occur in the region in jaws, since the  
30 uniaxial tensile forces typical of the test with the local pressures between the jaw and the specimen. These stresses are particularly high in the section of the specimen that is in the transition between the jaw region and the free region between jaws, since in this section the jaws tend to "bite" the specimen concentrating local stresses.

Standardized specimens for tensile testing, as per ASTM ES [176], on metallic materials have a geometry that has been designed to provide representative results. In general, these are "thinned" test tubes, flat or cylindrical, i.e. test tubes that have been 5 machined in such a way that their resistant section in the central area (the shaft) is lower than that of the ends (the heads). This geometry facilitates breakage in the shaft, the free region between jaws, and prevents premature breakage in jaws, the region in jaws.

10 There are situations in which this type of specimens are not appropriate for a correct characterization of a material. In a vehicle damping spring, for example, the most demanding stress states under operating conditions occur in the contour of the resistant section, since these are mainly torsional stresses. For this reason, it is important that a

15 tensile test is capable of characterizing the material near the surface; To this end, it is recommended that the test be carried out on a full-section bar and not on a machined specimen.

However, in general, it is not easy to carry out tensile tests

20 satisfactory sabre bars of constant section. To prevent the specimen from slipping, it is necessary to apply high pressures to the jaws; For this, the most demanding stress states occur, as mentioned above, precisely in the section of the specimen that is located in the transition between the jaw region and the free region between jaws, so that the break tends to

25 occur in this region, particularly at the end of the gag, i.e. at the point where the gag "bites" or grabs the specimen. In the event of breakage in the jaws, the test must be discarded.

### **DESCRIPTION OF THE INVENTION**

30

The present invention is established and characterized in the independent claim, while the dependent claims describe other physical characteristics of it.

The object of the invention is an adapter for grips of a tensile-compression testing machine. The technical problem to be solved is to configure this adapter in such a way as to avoid breakage in the grip area of the specimen to the jaws.

5 In view of the foregoing, the present invention relates to an adapter for grips of a tensile-compression testing machine, each jaw comprising a first major face of attachment to the machine, a second major face opposite the first major face, and a third major face joining the first and second major faces, two lateral faces, first and second,  
10 adjacent to the third major face and which also join the first and second major faces, where a test tube would be liable to be tested if the adapter of the invention were not included, as is known in the state of the art.

The adapter comprises two plates, each of which is in the shape of a prism  
15 rectangular and can be attached to each of the jaws; Each plate comprises a fourth major face that is facing the third major face of the corresponding jaw, a fifth major face opposite the fourth major face, a first minor face that joins the fourth and fifth major face and is on the side of with the first major face, a second minor face opposite the first minor face  
20 and which is on the side of the second major face, two lateral faces, third and fourth, adjacent to the fourth major face and which also join the fourth and fifth major faces; Each plate includes on its fifth major face a semi-cylindrical hollow from the first to the second minor face and whose longitudinal axis is aligned or parallel to the direction of movement of the jaws, so that

25 For each pair of jaws, two plates are arranged whose fifth major faces face each other so that their hollows are facing each other to form a cylindrical housing where a cylindrical specimen of constant section can be arranged, as is known in the state of the art.

30 The adapter is characterized by the fact that each plate is longer than the third largest face of the corresponding jaw, so that the fifth largest face of each plate extends over the specimen in a greater dimension than that of the corresponding third larger face.

The machine, the jaws and the specimen are not part of the invention, they are named because of their relationship with the adapter and because they help to better understand it.

An advantage of the adapter is that it minimizes the stresses at the ends of the  
5 specimen because it facilitates an effective grip of the specimen, producing a homogeneous distribution of pressures, avoiding "biting" the specimen in the grip area, where it receives direct pressure from the jaws, with less pressure in the jaws than is usually used.

10 Another advantage of the adapter is that a smooth transition is achieved between the stresses experienced by the specimen in the jaw region and in the free region between them.

Other advantages related to dependent claims are cited in the  
15 Detailed exposition below.

### **BRIEF DESCRIPTION OF THE FIGURES**

This descriptive report is complemented with a set of illustrative figures  
20 of the preferential example, and never limiting the invention.

Figure 1 shows a perspective view of the adapter arranged in jaws.

25 Figure 2 depicts a longitudinal section of the adapter and jaws in Figure 1.

### **DETAILED STATEMENT OF THE INVENTION**

30 Figure 1 shows an adapter (2) for grips (1) of a tensile-compression testing machine, not represented, where each jaw (1) comprises a first major face (1.1) for fixing to the machine, a second major face (1.2) opposite the first major face (1.1), and a third major face (1.3) that joins the first (1.1) and second major face (1.2), Side Sides, First (1.4)

and second (1.5), adjacent to the third major face (1.3) and also joining the first (1.1) and second major face (1.2). The adapter (2) comprises two plates (2.1), each in the form of a rectangular prism and which can be attached to each of the jaws (1); Each plate (2.1) comprises a fourth major face (2.11)

5 which is facing the third major face (1.3) of the corresponding jaw (1), a fifth major face (2.12) opposite the fourth major face (2.11), a first minor face (2.13) that joins the fourth (2.11) and the fifth major face (2.12) and is on the side of the first major face (1.1), a second minor face (2.14) opposite the first minor face (2.13) and which is on the side of the second major side (1.2),

10 two lateral faces, third (2.15) and fourth (2.16), adjacent to the fourth major face (2.11) and also joining the fourth (2.11) and fifth major face (2.12); Each plate (2.1) includes on its fifth major face (2.12) a semi-cylindrical hollowing (2.17) from the first (2.13) to the second minor face (2.14) and whose longitudinal axis is aligned with or parallel to the direction of movement of the jaws

15 (1), so that for each pair of jaws (1) two plates (2.1) are arranged whose fifth major faces (2.12) face each other make their hollows face each other (2.17) to configure a cylindrical housing where a cylindrical specimen (3) of constant section can be arranged. The characteristics described are clearly seen in the section of Figure 2, in which it is not shown that the

20 represents the test tube (3).

Each plate (2.1) is longer than the third major face (1.3) of the corresponding jaw (1), so that the fifth major face (2.12) of each plate (2.1) extends over the specimen (3) in a larger dimension than that of the

25 corresponding first face (1.3). That is, the adapter (2) rests on the specimen (3) at a greater length than the jaws (1). This provides a smooth transition between the stresses experienced by the specimen (3) in the jaw region (1) and in the free region between them. Specifically, an option that has been shown to be advantageous is that the length of each plate (2.1) is greater than the length of

30 the third largest face (1.3) in a dimension between two and five times the diameter of the specimen (3). Finally, it has been found as an appropriate option that the diameter of each hollow (2.17) is 0.02 mm greater than the diameter of the specimen (3).

An option that aids in the placement of the adapter (2) is that each plate (2.1) is arranged so that its first minor face (2.13) is flush with the corresponding first major face (1.1) of the jaw (1). Another flush that helps, either by itself or added to the one mentioned, is that each plate (2.1) is

5 arranged in such a way that its third side face (2.15) is flush with the corresponding first side face (1.4) of the jaw (1), and its fourth side face (2.16) is flush with the corresponding second side face (1.5) of the jaw (1).

10 Another option is that a mixture of oil and corundum powder is adhered to each hollow (2.17) in such a way as to increase the coefficient of friction between the specimen (3) and the plates (2.1). Specifically, this mixture means that the pressure that the jaws (1) can exert on the plates (2.1) to hold the specimen (3) is between 10 bar and 20 bar. For example, it has been found that a

15 pressure on jaws (1) of only 15 bar is sufficient, when, under normal conditions without the mixture of oil and corinth dust, approximately 70 bar is required to prevent the specimen from slipping (3).

To validate the correct functioning of this system, a  
20 experimental campaign consisting of 80 tensile tests on specimens (3) of 13.50 mm diameter constant-section steel, with the diameter of each hollowing out 13.52 mm, maintaining a distance between jaws (1) of 30 cm. In 77 of the 80 tests - more than 96% - a satisfactory test has been achieved with a break away from the jaw area (1) more than two diameters.

25

**DEMANDS**

- 1.-Adapter (2) for grips (1) of a tensile-compression testing machine, each jaw (1) comprising a first major face (1.1) of fixing to
- 5 the machine, a second major face (1.2) opposite the first major face (1.1), a third major face (1.3) that joins the first (1.1) and the second major face (1.2), two lateral faces, first (1.4) and second (1.5), adjacent to the third major face (1.3) and which also join the first (1.1) and the second major face (1.2), two plates (2.1), each in the form of a rectangular prism and which can be attached to
- 10 each of the jaws (1); Each plate (2.1) comprises a fourth major face (2.11) that is facing the third major face (1.3) of the corresponding gag (1), a fifth major face (2.12) opposite the fourth major face (2.11), a first minor face (2.13) that joins the fourth (2.11) and the fifth major face (2.12) and is on the side of the first major face (1.1), A Second Minor Face (2.14)
- 15 opposite the first minor face (2.13) and which is on the side of the second major face (1.2), two lateral faces, third (2.15) and fourth (2.16), adjacent to the fourth major face (2.11) and which also join the fourth (2.11) and the fifth major face (2.12); Each plate (2.1) includes on its fifth major face (2.12) a semi-cylindrical hollowing (2.17) from the first (2.13) to the second minor face (2.14) and
- 20 whose longitudinal axis is aligned with or parallel to the direction of movement of the jaws (1), so that for each pair of jaws (1) two plates (2.1) are arranged whose fifth major faces (2.12) face each other so that their hollows face each other (2.17) to form a cylindrical housing where a cylindrical specimen (3) of constant section can be arranged, **characterized by** the fact that
- 25 Each plate (2.1) is longer than the third major face (1.3) of the corresponding jaw (1), so that the fifth major face (2.12) of each plate (2.1) extends over the specimen (3) in a larger dimension than that of the corresponding third major face (1.3).
- 30 2.-Adapter (2) according to claim 1 wherein the length of each plate (2.1) is greater than the length of the third largest face (1.3) in a dimension between two and five times the diameter of the specimen (3).
- 3.-Adapter (2) according to claim 1 wherein the diameter of each

Cupping (2.17) is 0.02 mm greater than the diameter of the specimen (3).

4.-Adapter (2) according to claim 1 in which each plate (2.1) is arranged in such a way that its first minor face (2.13) is flush with the corresponding one  
5 first major face (1.1) of the jaw (1).

5.-Adapter (2) according to either claim 1 or 2 in which each plate (2.1) is arranged in such a way that its third side face (2.15) is flush with the corresponding first side face (1.4) of the jaw (1), and its fourth side  
10 lateral (2.16) is flush with the corresponding second lateral face (1.5) of the jaw (1).

6.-Adapter (2) according to claim 1 in which a mixture of oil and corundum powder is attached to each hollowing out (2.17) so as to increase the  
15 coefficient of friction between the specimen (3) and the plates (2.1).

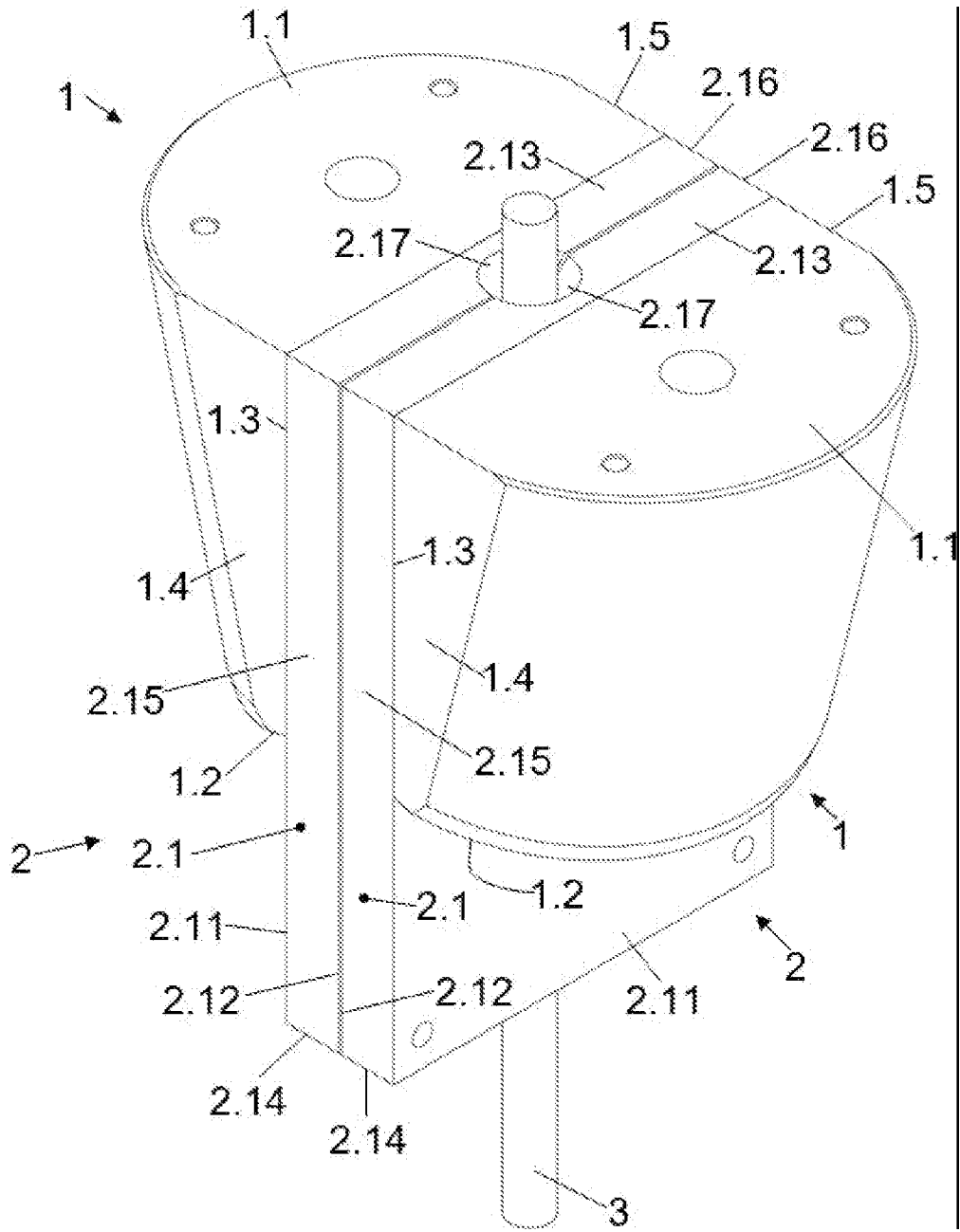

**Fig.1**

